

# FRANGITALIA

## HORIZONTAL LOUVER SYSTEM

**CHARACTERISTICS:** FRANGITALIA, is an excellent solution for security and privacy requirements. FRANGITALIA's electro-fused louver system has two versions offering either 80% or 100% visual obstruction.

**APPLICATIONS:** FRANGITALIA panels are ideal for residential and commercial environments such as balconies, perimeter fencing, sunscreens, gates & doors, ventilation openings, and parking garages.

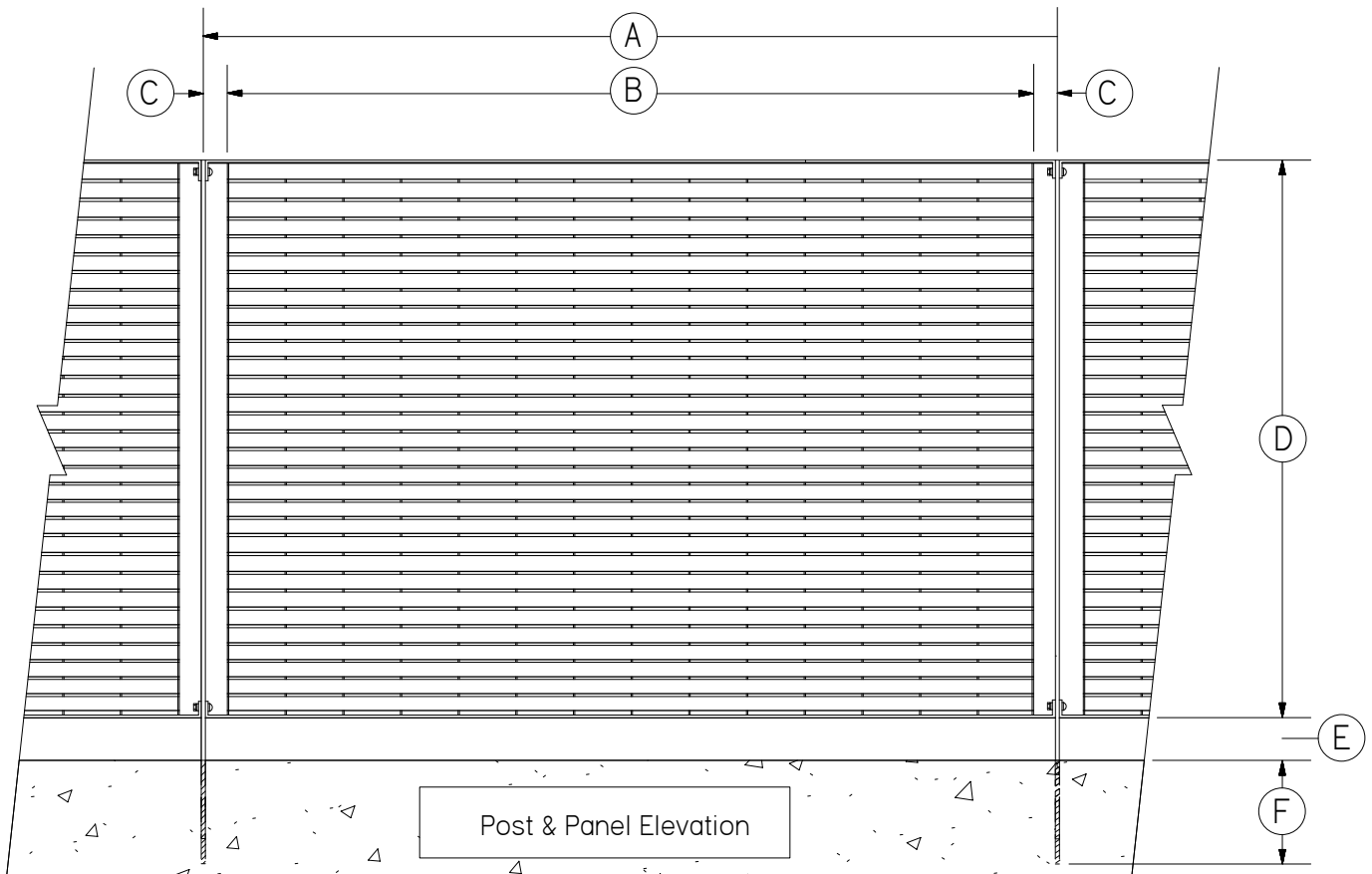
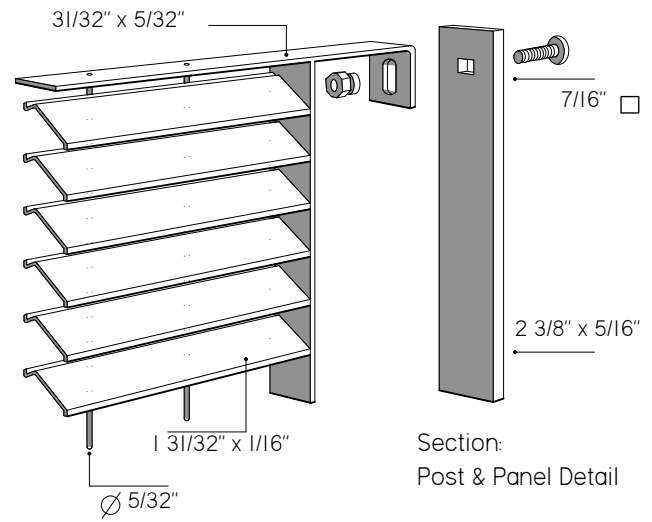

(A)	POST SPACING	78 3/4" Maximum	<b>ADDITIONAL SPECIFICATIONS</b> Grill Weight is approx. 4.05 lbs. per sq. ft. Steel meets ASTM A-36 standard Electrofused Steel Construction Hot-dip Galvanized to ASTM-123 Standard Polyester Powder-coated or Epoxy Wet-coat
(B)	PANEL WIDTH	73 11/32" Maximum	
(C)	LUG PROJECTION	2 1/2" Maximum	
(D)	PANEL HEIGHT	Up to 144" High	
(E)	CLEARANCE	4" Maximum	
(F)	POST EMBEDMENT	7" Minimum	



Industries, Inc.